

**"BEYOND THE CLASSROOM"
ENGLISH SELF-STUDY GUIDE**

School _____ City _____
 Teacher's name _____
 Student's name _____
 Grade _____ SEXTO _____ Level _____ A1 _____

ORIENTACIONES PARA LOS PADRES DE FAMILIA

Esta Guía de aprendizaje de inglés para el trabajo en casa, se preparó con el fin de ayudar a su hijo(a) a reconocer el vocabulario relacionado con los miembros de la familia en inglés, en forma oral y escrita. Para aplicarlo en la elaboración de su árbol Genealógico con la ayuda de sus abuelos y demás miembros de su familia. Su hijo(a) deberá dedicar una hora y media para desarrollar toda la guía. El trabajo aquí descrito se relaciona con las páginas 26 y 27 del libro del estudiante ENGLISH PLEASE! Fast Track 1, que está disponible en la plataforma Colombia Aprende. Se adjuntaron las páginas del libro al final de la guía para quienes no tienen acceso a internet.

-La actividad 1, es un ejercicio de reconocimiento de vocabulario de los miembros de la familia en inglés. Para ello el estudiante debe buscar las palabras que no entienda en el diccionario.

-La actividad 2, (Language Awareness) es un ejercicio de comprensión de la estructura para hablar cómo están relacionados los miembros de la familia. Debe ver el árbol familiar, y los ejemplos en el language box. Después responder las preguntas sobre la familia Williams, éstos se encuentran en los ejercicios A, opción múltiple, y B, escribir las relaciones familiares.

La actividad 3, es un ejercicio de lectura, y con base en esa información, completa el árbol genealógico y responde las preguntas de falso y verdadero. Éste se base en el punto 3 de la página 26 del libro del estudiante del texto English Please! Fast Track 1.

-La actividad 4: El estudiante tendrá como base la Familia Williams. Mirar los ejemplos dados. Debe dibujar su árbol genealógico con al menos 6 miembros de la familia. Allí debe escribir oraciones que describan cómo están relacionados. Luego, debe hacer una grabación en donde describe su árbol. (Ya ha escrito las oraciones) y enviarlo a un compañero vía WhatsApp.

-La actividad 5: En ésta su hijo (a) debe evaluar lo aprendido con esta guía. Por favor haga las preguntas que están al final de ésta guía.

Todas las actividades tienen ejemplos y las respuestas de los ejercicios también se encuentran al final para que su hijo(a) verifique que sus respuestas sean correctas.

WELCOME TO THIS SELF-STUDY GUIDE

This English self-study guide helps you practice vocabulary related to family members. It starts with a vocabulary activity and in the language awareness section, read the examples about describing family relationships. This section has two exercises for you to practise. Then, in the reading task there are two exercises and finally, you should describe your family tree and send it to a classmate.

Topic	Skill(s)	Grammar	Vocabulary	Function(s)
Family Members	Reading and speaking	Using verb to-be with family.	Family's Member Female-Male or Both	Identify the family members.



GET READY

Study time needed:

1.30 hours

Resources:

Mobile phone, dictionary, pencil, and written instructions about family vocabulary.

Text books: English please !1, Student's book.

Textbooks Links:

English Please 1 Student's book, Module 1 unit 1 Lessons 4 page 22

<http://www.colombiaprende.edu.co/es/node/123812>

LEARNING OBJECTIVES

What will you learn /practise/ reinforce with these activities?

This lesson helps the student recognize their family tree.

- To practice vocabulary related to the Family.
- To identify family relationships.
- To describe my family tree.

LEARNING STRATEGIES

What can do to achieve the objectives?

- Read the instructions for each exercise carefully.
- look at the examples given before to develop each exercise.
- Write in your notebook any new vocabulary learned, and their meaning in English. Use a dictionary only if it is absolutely necessary.
- Before recording the description practise reading out loud.

ACTIVITIES

ACTIVITY 1

Grandmother wife grandfather mother sister daughter son husband

A. VOCABULARY TASKS (20 minutes)

Label the family members with the words from the box

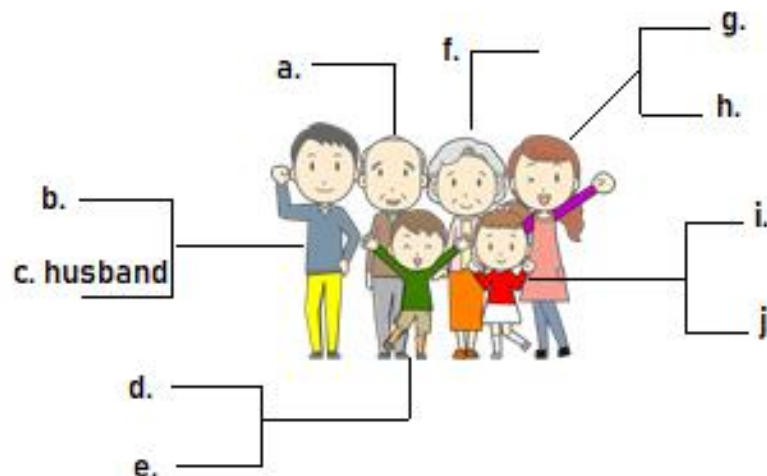



B. Put the words in the correct column. Look at the example

MALE	FEMALE
Brother	Sister

ACTIVITY 2. LANGUAGE AWARENESS (20 minutes)

Language to talk about my family.

The Williams Family

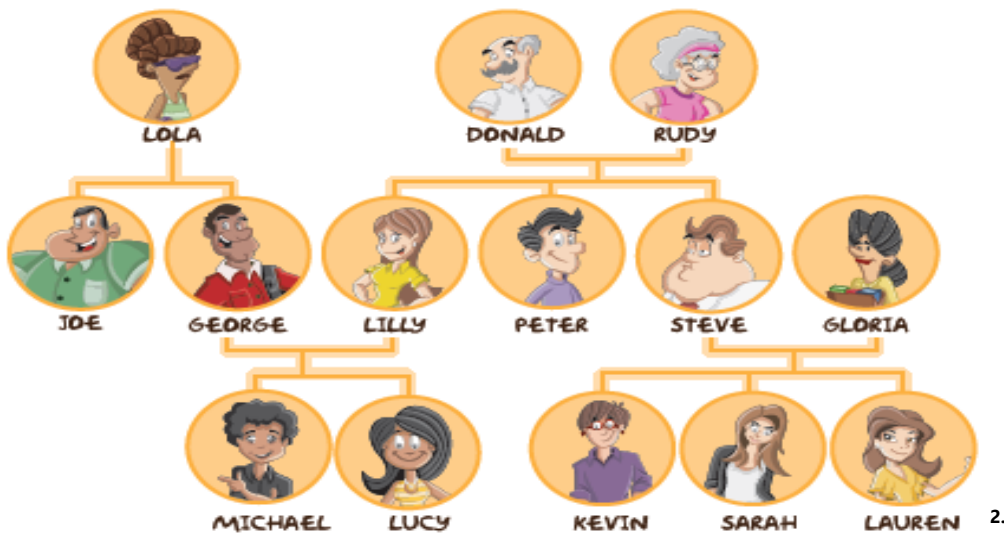

LANGUAGE BOX

's expresses possession. Look at the examples

George is Lola's son / Lola's son is George = George is the son of Lola.
Donald is Peter's father/ Peter's father is Donald = Donald is the father of Peter

- My sister's house.
- Michael's sister is Lucy
- Peter's sister is Lilly.
- Steve's son is Kevin.

A. Look at the Williams family tree and choose the correct name.

- | | | | |
|----------------------------|---------------------------|----------------------------|---------------------------|
| 1. Lucy's grandmother is | A. Rudy | B. Lilly | C. Gloria |
| 2. Kevin's uncle is | A. Steve | B. Peter | C. Joe |
| 3. Lola's granddaughter is | A. Lucy | B. Sarah | C. Lauren |
| 4. Gloria's husband is | A. Joe | B. George | C. Steve |
| 5. Sarah's parents are | A. Lilly and Peter | B. Steve and Gloria | C. Donald and Rudy |



B. Write sentences with the names and people.

- a. 'Lilly is my daughter.' (Donald) Donald is Lilly's father.
- b. 'Lauren is my sister.' (Kevin) Kevin is _____
- c. 'Donald is my grandfather.' (Michael) _____
- d. 'George is my husband.' (Lilly) _____
- e. 'Rudy is my mother.' (Peter) _____

Now, compare your answers with the answer key at the end of this guide.

ACTIVITY 3. READING TASK (20 minutes)

A. Read about Sandy's family and complete her family tree

Hi, I'm Sandy and this is my family tree. My parents are Nancy and José. They are good parents. I'm an only child, but I have two twin cousins. Carlos is very clever and Cesar is funny. They are my Aunt Patricia's sons. She is very nice. Uncle James is their father. My mum's brother is Tom and he is single. He's my favourite uncle. He's great. Doris and William are married. They are my father's parents. Martha and Juan are my mother's parents. They are divorced. My grandmothers are both lovely and kind. My grandfathers are amazing!!

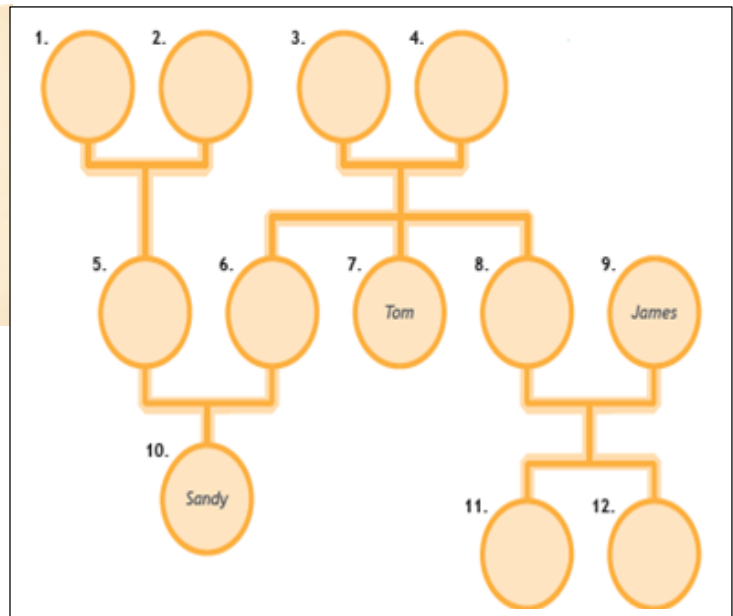

B. Read the sentences about Sandy's family and say if they are True or False.

- 1. Sandy's parents are José and Nancy. True
- 2. Sandy has two brothers _____
- 3. Cesar and Carlos are Sandy's cousins _____
- 4. Tom is Sandy's uncle _____
- 5. Tom is married _____

ACTIVITY 4

Speaking TASKS. My Family tree. (20 minutes)

Preparation



- 1. Draw your family tree. Include at least 6 family members.
- 2. Write down the family relationships. Look at the model in the writing and the language awareness.
- 3. Describe the family tree, record your description and send it via WhatsApp to a classmate.



Before you send your recording check.

	Yes	No yet
I included at least 6 family members		
I practiced the pronunciation		
I described 5 family relationships		

5.SELF-ASSESSMENT TASKS (10 minutes)

Check your progress!	 4	 5	 6	Discuss with your parents, then answer the questions below
	Very well	Quite well	With difficulty	
I can identify vocabulary related to family members				How many words did you learn? _____
I can identify family relationships				How many family relationships did you identify in the reading
I can describe my family tree				Who did you include in your description.

THIS IS THE END

Congratulations, you can do amazing things, continue practicing the vocabulary about The Family member and how to describe them. Also get to know more about your family tree. You can check the useful resources as well.

USEFUL RESOURCES

- <https://learnenglish.britishcouncil.org/skills/reading/beginner-a1>
- <https://learnenglish.britishcouncil.org/category/language-level/beginner-a1>
- <https://learnenglishteens.britishcouncil.org/grammar/beginner-grammar>
- Online English-Spanish dictionary
<https://dictionary.cambridge.org/dictionary/english-spanish/>
- Family members video.
<https://www.youtube.com/watch?v=FHaObkHEkHQ>
- Way to Go 6th. Grade- WorkBook. Module 1, Unidad 3, pag.11
<http://aprende.colombiaaprende.edu.co/es/node/94010>



ANSWER KEY

VOCABULARY TASKS

- A. a. Grandfather. b. Father c. husband d. son/ brother e. brother/
f. grandmother g. mother/wife h. wife/mother i. sister/daughter j.
daughter/sister

B.

MALE	FEMALE
Brother	Sister
Father	Mother
Son	daughter
grandfather	grandmother
Husband	wife

LANGUAGE AWARENESS

Answers (Activity 2, A)

1 A 2 B 3 A 4 C 5 B

Answers (Activity 2, B)

- Donald is Lilly's father.
- Kevin is Lauren's brother.
- Michael is Donald's grandson.
- Lilly is George's wife.
- Peter is Rudy's son.

READING TASK

A. Sandy's Family tree

1. Doris 2. William 3. Martha 4. Juan 5. José 6. Nancy 7. Tom
8. Patricia 9. James 10. Sandy 11. Carlos 12. Cesar

B. True or False

1. True 2. False 3. True 4. True 5. False

ORIENTACIONES FINALES PARA LOS PADRES DE FAMILIA

Una vez su hijo o hija haya terminado las actividades de esta guía, trate de reunirse con su hijo(a), tome el álbum familiar y amplíe el árbol Genealógico con los parientes que el desconocía. Motivarlo(a) para que haga ejercicio de escritura y escucha en inglés.

Por favor hágale las siguientes preguntas

- ¿Qué actividad te gustó más?
- ¿qué actividad fue más difícil?
- ¿Cómo se dice esposa en inglés?
- ¿Qué miembros de la familia incluiste en el árbol genealógico?

Sabemos del apoyo y dedicación de ustedes padres de familia para con sus hijos. Del



acompañamiento en el desarrollo de las actividades de la Guía de trabajo académico. Gracias por unirse a nuestros esfuerzos. Felicitaciones a ustedes padres de familia y a sus hijos por el compromiso con las actividades académicas programadas.

AUTHOR(S)

Name	OFELIA VARGAS LONDOÑO	CIELO BARRETO ROMERO	
Email	ofitovargas@gmail.com	cielobarretoromero@gmail.com	
School	Francisco De Miranda(Rovira-Tolima)	INST EDUC CIUDAD LUZ	

LINKS OF IMAGES

1. Image retrieved from <https://publicdomainvectors.org/en/free-clipart/Happy-family-vector-clip-art/75933.html> with a free for commercial use license.
2. Ministerio de Educación Nacional (n.d). English, please! 1 Fast Track. Bogotá D.C. – Colombia. P.27. Retrieved from www.colombiaaprende.edu.co/colombiabilingue.
3. Ministerio de Educación Nacional (n.d). English, please! 1 Fast Track. Bogotá D.C. – Colombia. P.28. Retrieved from www.colombiaaprende.edu.co/colombiabilingue.
4. Image retrieved from <https://pixabay.com/vectors/smiley-face-grin-smile-happy-icon-304270/> with a free for commercial use license.
5. Image retrieved from <https://pixabay.com/vectors/smiley-emoticon-happy-face-icon-1635449/> with a free for commercial use license.
6. Image retrieved from <https://pixabay.com/vectors/smiley-emoticon-undecided-unsure-1635455/> with a free for commercial use license.



English Please Fast Track 1. Page 22

4

Lesson 4

Focus on vocabulary

Get Ready!

1. Write the family members in your notebook.

1.

2.

3.

4.

5.

6.

2. Find more family members and complete the chart in your notebook.



Female	Male	Plural



English Please Fast Track 1. Page 27

Focus on language

4. Look at the Williams family tree and choose the correct name.

- | | | | |
|----------------------------|--------------------|---------------------|--------------------|
| 1. Lucy's grandmother is | A. Rudy | B. Lilly | C. Gloria |
| 2. Kevin's uncle is | A. Steve | B. Peter | C. Joe |
| 3. Lola's granddaughter is | A. Lucy | B. Sarah | C. Lauren |
| 4. Gloria's husband is | A. Joe | B. George | C. Steve |
| 5. Sarah's parents are | A. Lilly and Peter | B. Steve and Gloria | C. Donald and Rudy |

The Williams Family

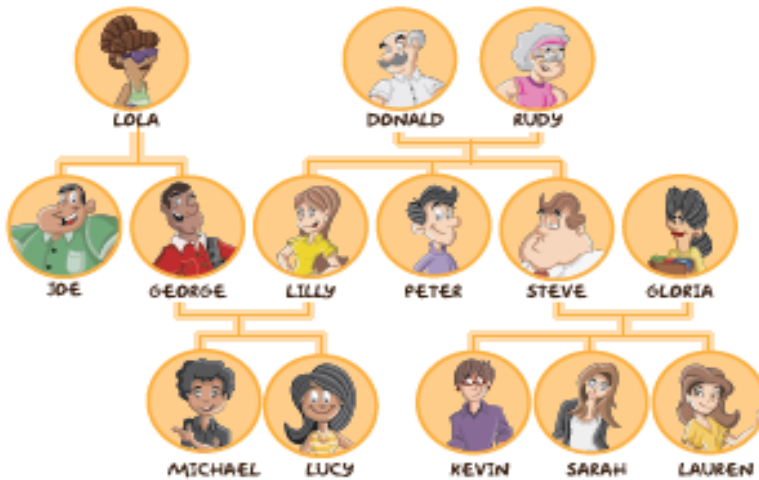

Useful language

- How do you say these sentences in Spanish?
- Look at the apostrophes in all the sentences, e.g., *Lucy's father*.
Important!
 George is the father of Lucy.
 George is Lucy's father.

5. In your notebook, write sentences to answer the questions.

- Who are Michael's parents? *George and Lilly are Michael's parents.*
- Who is Joe's nephew? _____
- Who is Steve's sister? _____
- Who are Sarah's grandparents? _____
- Who is Lola's granddaughter? _____

6. Write sentences with the names and people.

- 'Lilly is my daughter.' (Donald) *Donald is Lilly's father.*
- 'Lauren is my sister.' (Kevin) *Kevin is _____*
- 'Donald is my grandfather.' (Michael) _____
- 'George is my husband.' (Lilly) _____
- 'Rudy is my mother.' (Peter) _____



English Please Fast Track 1. Page 28

7. Read about Sandy's family and complete her family tree in your notebook.

Hi, I'm Sandy and this is my family tree. My parents are Nancy and José. They are good parents. I'm an only child, but I have two twin cousins. Carlos is very clever and Cesar is funny. They are my Aunt Patricia's sons. She is very nice. Uncle James is their father. My mum's brother is Tom and he is single. He's my favourite uncle. He's great. Doris and William are married. They are my father's parents. Martha and Juan are my mother's parents. They are divorced. My grandmothers are both lovely and kind. My grandfathers are amazing!!

Glossary

twin = gemelo/a
 single = soltero/a
 married = casado/a
 divorced = divorciado/a



B. Say it!

Listen and repeat.
 When we add 's' to singular words that end in 's', we add an extra syllable at the end of the word.
 Carlos's sister.

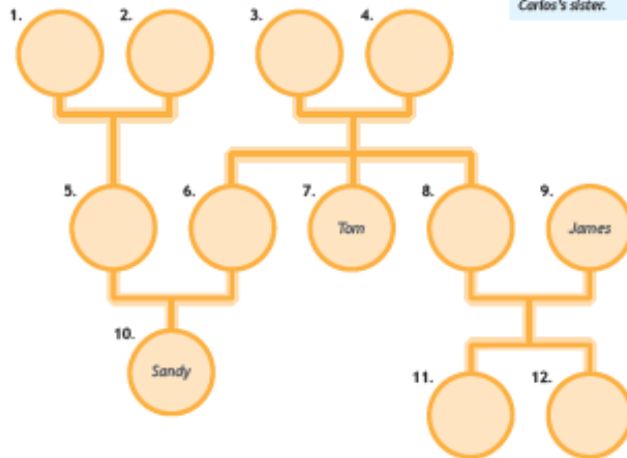

9. Listen and repeat these sentences.

- Richard's brother is Ken.
- My father's family is big.
- Jenny is Carlos's sister.
- The children's aunts are in the park.
- Chris's niece is my daughter.